

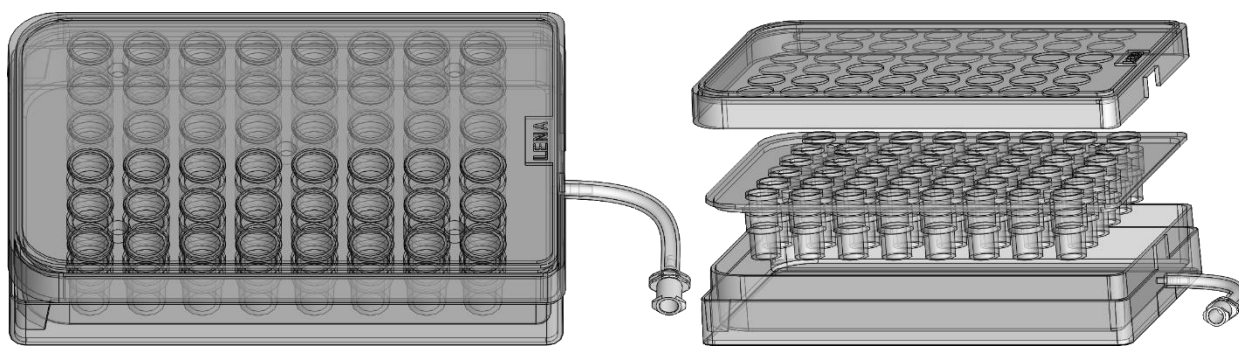

Innovative 3D Cell Culture Tools for Life Sciences

PerfusionPal 48-well Starter System INSTRUCTIONS



PerfusionPal: U.S. PATENT NO. 9,701,938

SeedEZ: U.S. PATENT NO. 9,334,473

PerfusionPal AND **SeedEZ** ARE TRADEMARKS OF LENA BIOSCIENCES, INC.

FOR IN VITRO RESEARCH USE ONLY.

NOT FOR USE IN DIAGNOSTIC OR THERAPEUTIC PROCEDURES. NOT FOR USE IN ANIMALS OR HUMANS.

©2023 LENA BIOSCIENCES. ALL RIGHTS RESERVED.

MATERIALS NEEDED AND NOT PROVIDED

- Sterile forceps, and a larger Petri dish or a multiwell plate
- A small stand or step-stool

INSTRUCTIONS

All steps should be carried out in a cell culture hood using proper sterile techniques.

1. Put package contents into the hood.
2. Place the pump onto a stand or step-stool outside of the hood.
3. Open the pouch with tubing. Attach one end of the tubing to the luer fitting on the tray tube. Attach the other end of the tubing to the luer fitting on the syringe provided with the package.
4. Place the syringe into a syringe pump (See **LOADING A SYRINGE**).
5. Prime the system:
 - A. Add 75 mL of blood substitute to the tray.
 - B. Place multiwell insert into tray and cover with lid.
 - C. Set the syringe pump to withdraw a volume of 20 mL at a flow rate of 1 mL/min (See **PRIMING PerfusionPal**).
 - D. Without disconnecting any tubing, remove the syringe from the pump, point it upwards and tap on syringe to dislodge any small bubbles.
 - E. With the syringe still pointed upwards, slowly press the plunger and ensure that all accumulated air is passed through the tubing and released into the tray. There should be no bubbles present in the syringe or in the tubing at this point.
 - F. Continue to press the plunger to the 5 mL mark. If the plunger is already past this point, place the syringe back into the syringe pump and set the pump to withdraw at 1 mL/min until it reaches the 5 mL mark.
6. Place the syringe back into the syringe pump.
7. Add 300 µL medium into each well.
8. Seed cells into SeedEZ scaffolds using the desired method (See **SEEDING CELLS**).
9. Place scaffolds into wells (See **PLACEMENT OF 3D CULTURES INTO THE INSERT**).
10. Carefully place PerfusionPal into the incubator. Keep it horizontal during transfer from the hood to incubator. Slide the steel sheath on the tubing into position between the incubator door and gasket to prevent crushing of the tubing.
11. Put the pump on the stand outside the incubator at the same or lower level than that of the PerfusionPal in the incubator to prevent degassing of the blood substitute.
12. Set the desired **continuous** flow rate for cyclic infusion/ withdrawal with a target volume of 17 mL. For example, 0.047 mL/min infusion and 0.047 mL/min withdrawal results in two complete cycles (2x up and 2x down), or 16 culture volume exchanges per day. (See **PERFUSING with PerfusionPal**; see **TABLE OF FLOW RATES**; see **FEEDING CELLS** for media exchange protocol).

NOTES

- Avoid manual withdrawal of the blood substitute (pulling of the syringe plunger) to prevent air bubble formation. Since the blood substitute is viscous, small bubbles will occasionally form in the tubing or syringe. This is normal and does not affect the performance of PerfusionPal™.
- After priming, the 5 mL of blood substitute in the syringe acts as a buffer for bubbles. Although rare, in a long-term culture, a bubble in the syringe may grow large enough to enter the tubing during infusion. Should this occur, disconnect the syringe from the tubing, point it upwards, purge the air, and reconnect. Doing this should not introduce bacterial contamination as the blood substitute contains no nutrients to support their growth.
- To prevent accidental spills, place PerfusionPal into a glass staining/fixing dish (without the lid). Since the glass dish is heavy, it is easy to keep PerfusionPal leveled during transport to and from the incubator for feedings. You may also secure the tube by taping it to the side of the glass dish.
- **Blood substitute does not evaporate and can be reused.** After a perfusion study, carefully collect the liquid and ensure there is no medium floating on top. Sterile filter using a 0.2 µm PES bottle-top filter and reuse.
- DO NOT dispose of blood substitute in the sink or in biohazard waste that will be incinerated. Blood substitute residue should be removed with a Kimwipe and disposed of in the regular trash, if possible.

SEEDING CELLS

SeedEZ scaffolds are versatile and compatible with various cell culture coatings, extracellular matrices and hydrogels to ensure optimal environment for cells.

Method 1 – Uncoated SeedEZ

Using sterile forceps, transfer SeedEZ scaffolds to a multiwell plate or petri dish. Deliver 30 µL of cell suspension using a micropipette. Allow few minutes for cells to settle and proceed to Step 8.

Method 2 – Pre-coated SeedEZ

SeedEZ scaffolds can be coated (e.g. Poly-D-Lysine, Collagen etc.) prior to addition of cells. To coat the scaffolds, use standard protocols for flat disposables like Petri dishes and multiwell plates.

Coating the scaffolds:

- Transfer SeedEZ scaffolds to a multiwell plate or a large petri dish using sterile forceps.
- Deliver 30 µL or more coating liquid. It should be enough volume to completely wet the scaffold using a micropipette.
- Incubate as necessary.

- After incubation, aspirate the coating liquid from the scaffold. The scaffold will turn white when dry. This drying step should be repeated after any rinses that are performed.

Cell seeding:

- Deliver 30 μ L of cell suspension using a micropipette.
- Allow 5 minutes (or longer) for cells to settle and adhere.
- Proceed to Step 8.

Method 3 – Seeding in a hydrogel

SeedEZ scaffolds (either uncoated or coated) can be seeded with cells in a hydrogel. The following example is for Matrigel®. Using forceps, transfer SeedEZ scaffolds to the *top surface* of the wells of a 96-well plate. The small contact area between the scaffold and the top of the wells of a 96-well plate will prevent Matrigel from sticking and allow easy transfer of scaffolds after seeding. Deliver 30 - 40 μ L of cell suspension in hydrogel using a micropipette (depending on the viscosity of the hydrogel, more volume may be required to completely wet the scaffold). Leave 96-well plate without the lid and place into a larger, sterile, lidded glass staining/fixing dish. Incubate according to hydrogel's protocol (for Matrigel®, we recommend incubating for 10 minutes at 37 °C). Proceed to Step 8.

Method 4 – Dipping into cell suspension

Instead of using a micropipette with any of the previous methods, SeedEZ scaffolds can be directly dipped into a cell suspension (in medium or hydrogel) until the scaffold completely wets. We recommend this method for those hydrogels that are difficult to dispense using a micropipette. To prevent hydrogel from sticking to the surface of the dish during incubation, place the scaffolds onto a 96-well plate as described in Method 3. Proceed to Step 8.

PLACEMENT OF 3D CULTURES INTO THE INSERT

- Using forceps, carefully transfer seeded scaffolds to PerfusionPal wells by lowering scaffold onto the surface of the medium at a slight angle, allowing air to escape as the scaffold is lowered.
- Seat the scaffolds by either:
 - A. **Using the included seating insert:** Set it on top of the scaffolds in the multiwell insert and gently press downward. Gently lift to remove and verify that the scaffolds are seated properly. If a scaffold is not seated properly, use forceps to pick it up, lay it on the medium, and use the seating insert again.
 - B. **Without using the seating insert:** Use forceps or a pipet tip and gently press down the edges of each scaffold to ensure that it is resting on the seat.
- Cover PerfusionPal plate with the lid.

FEEDING CELLS

Removal of PerfusionPal from the incubator for feeding should be done near the end of an up-stroke, i.e. at the end of infusion when the medium level in the wells is at its highest position (fully infused), to prevent medium from exiting the bottom of the wells due to tilting. If this happens, it will not affect the function of the system, but medium may need to be added to the well to correct the volume.

When changing medium, exchange half the media from each well (150 μ L) to ensure that cultures are always submerged. **Since the liquid level in all wells is connected via the Blood Substitute, removal of media in one well will lower the media level in the other wells. Therefore, it is recommended to sequentially remove and add medium to individual wells or to small subsets of wells (e.g. replicates) to ensure sufficient media accessibility in every well.**

For long-term studies, account for evaporative losses of the media in your incubator by adding more media to wells during media exchanges. For example, remove 150 μ L and add 200 μ L at 1 week. These values are for guidance only. The actual values will depend on humidity control in your incubator. Please ensure that the water pan in your incubator is filled with deionized water during perfusion.

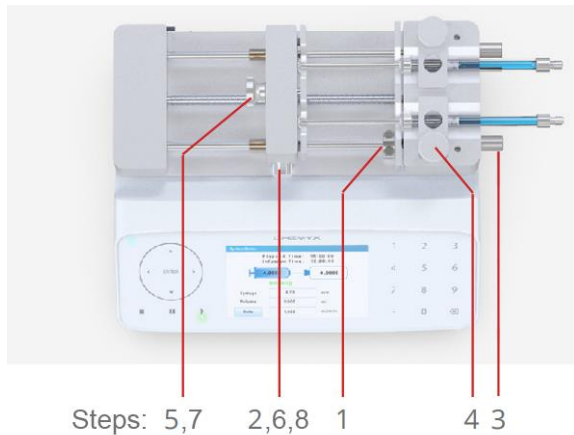
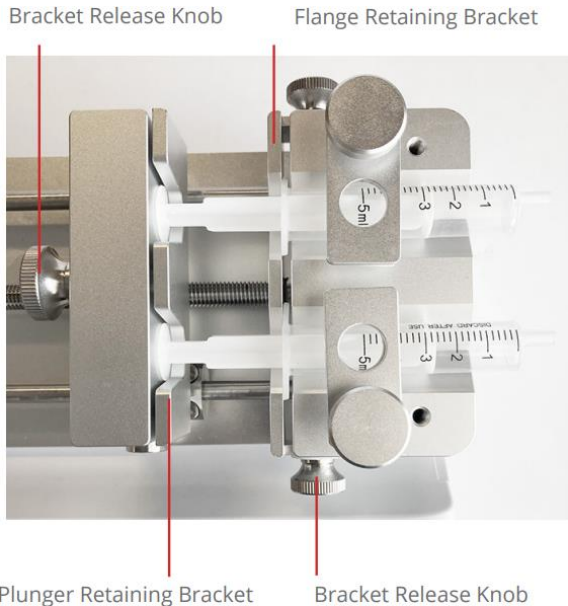

LOADING A SYRINGE

Step numbers correspond to numbers in diagrams on the left

1. The infusion safety collar is already in the proper position.
2. While pressing in the block release button, slide the pusher block all the way to the left.
3. Loosen the screw knobs for the flange retaining bracket and adjust the bracket such that the flange of the syringe barrel will fit in between. Do not tighten the bracket, yet.
4. Pull up on the spring-loaded syringe clamp and place the syringe in one of the channels of the holder block. Ensure that the flange of the syringe barrel is flush against the edge of the holder block. Slowly lower the syringe clamp to secure the syringe in place.
5. Loosen the bracket clamp knob for the plunger retaining bracket and adjust the gap such that the plunger cap of the syringe may fit.
6. Press the block release button and slide the pusher block to the right until it is flush against the syringe plunger. The plunger cap for the syringe should fit in the gap between the bracket and the pusher block.
7. Tighten the bracket clamp knob for the plunger retaining bracket to secure the syringe plunger in place.
8. Move the flange retaining bracket flush against the flange of the syringe barrel and tighten the bracket clamp knobs to secure the syringe barrel flange in place.

Front Panel of Pump

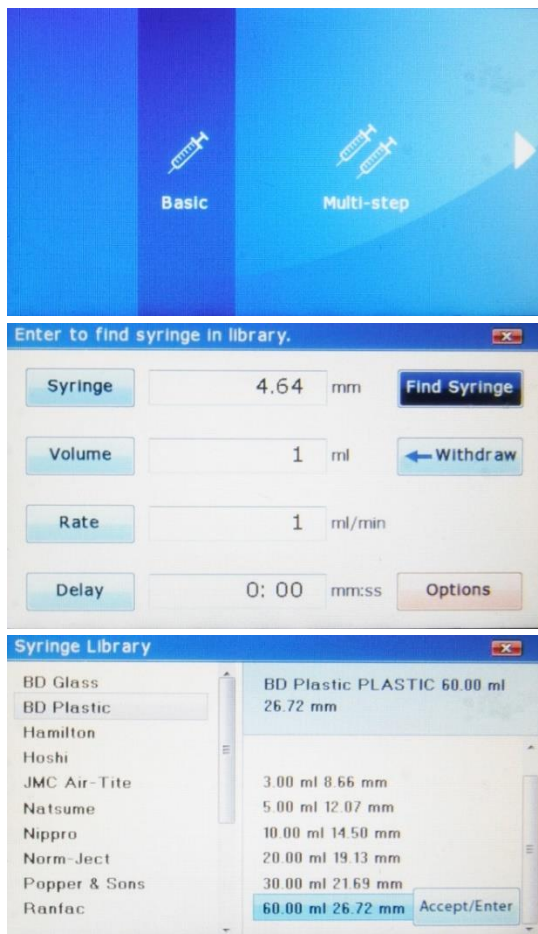

PRIMING PerfusionPal

1. Select **Basic** from the main menu using the Navigation Keypad or Touchscreen. Press the **Stop** button repeatedly to get to the main menu, if necessary.
2. The Basic menu will appear and indicate the diameter of the currently selected syringe, the volume to infuse or withdraw, and the flow rate.
3. Choose **Find Syringe** to enter the syringe library.
4. Select **BD Plastic** in the left column and **60.00 ml 26.72 mm** from the right column. If a smaller syringe is provided in the package, read its volume and select it from the drop-down menu.
5. Select **Accept/Enter**
6. The Basic menu will reappear and the syringe diameter should read 26.72 mm for a 60 ml syringe.

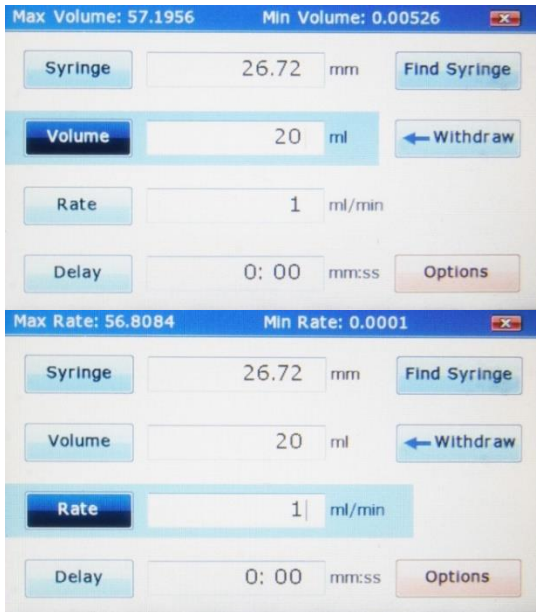

System Running

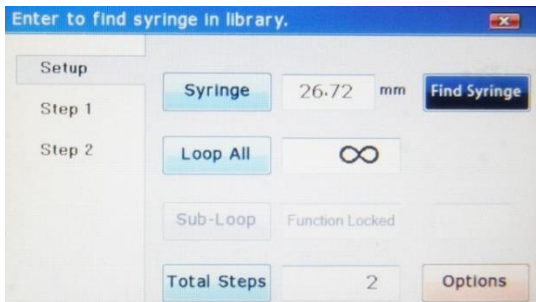
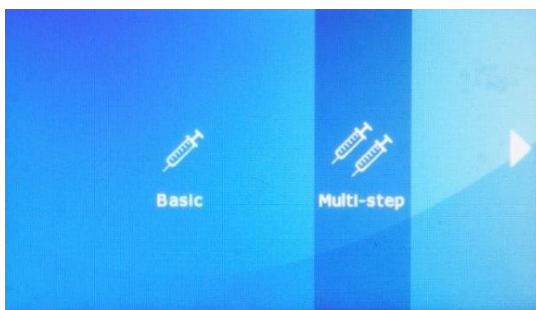
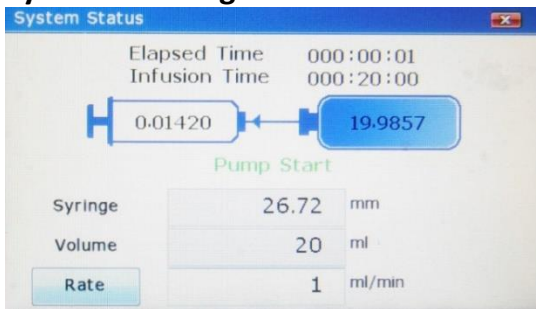

7. Select **Volume** and use the Numeric Keypad to enter a target volume of **20 mL**.
8. The button to the right of the volume should read **Withdraw**. If it reads **Infusion**, select it to toggle it to **Withdraw**.
9. Select **Rate** and use the Numeric Keypad to enter a flow rate of **1 ml/min**.
10. The display should read exactly as shown on the left.
11. Press **Start** on the Pump Controls to begin priming the system.
12. The screen shown on the left should appear, indicating how much liquid has been withdrawn and the elapsed time.

PERFUSING WITH PerfusionPal

1. Select **Multi-step** from the main menu using the Navigation Keypad or Touchscreen. Press the **Stop** button repeatedly to get to the main menu, if necessary.
2. The Multi-step menu will appear and indicate the diameter of the currently selected syringe, the number of times to loop all steps, and the total number of steps.
3. The diameter of the syringe should be 26.72 mm for a 60 ml syringe. If it not, enter the syringe library as before and choose **BD**

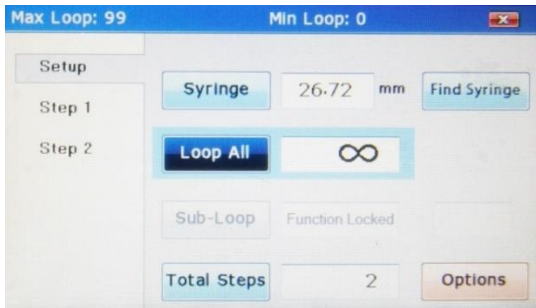

Settings for Step 1

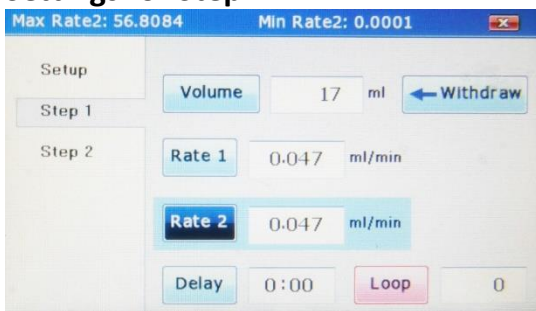

Settings for Step 2

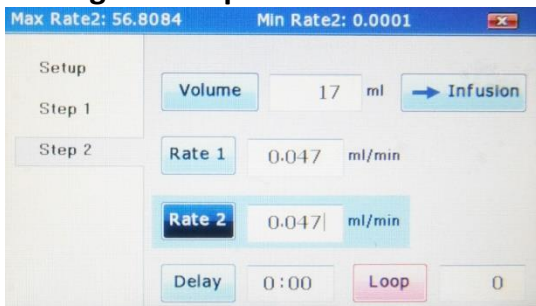

System Running

4. Select **Loop All** and set the desired number of loops. If continuous flow is desired, use the Numeric Keypad to enter "00" to set the number of loops to infinity as shown.
5. Select **Step 1** and the menu for Step 1 of the loop will appear.
6. Select **Volume** and use the Numeric Keypad to set a target volume of **17 mL**.
7. The button to the right of the volume should read **Withdraw**. If it reads **Infusion**, select it to toggle it to **Withdraw**.
8. Select **Rate 1** and use the Numeric Keypad to enter a flow rate of **0.047 ml/min**.
9. Selecting **Rate 2** will automatically set it to the same rate as **Rate 1**. This will result in a constant flow rate.
10. Select **Step 2** and input the same settings for **Volume (17 mL)** and **Rate (0.047 ml/min)**.
11. The button to the right of the volume should read **Infusion**. If it reads **Withdraw**, select it to toggle it to **Infusion**.
12. Press **Start** on the Pump Controls to begin perfusion.
13. The screen shown on the left should appear, indicating the status of the flow of liquid (including direction), elapsed time, and the count of the number of loops completed.

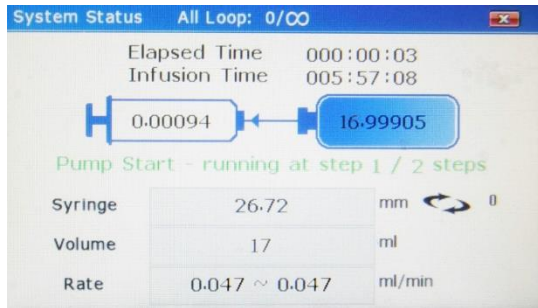

14. When changing medium, use **Pause** on the Pump Controls so that the perfusion will continue from the same point.

TABLE OF FLOW RATES

Flow Rate (mL/min)	Time to complete one step (withdrawal or infusion) (hrs)	Time to complete two complete cycles* (hrs)
0.047	6.03	24.1
0.049	5.78	23.1
0.054	5.25	21.0
0.060	4.72	18.9
0.063	4.50	18.0
0.071	3.99	16.0

** 1 complete perfusion cycle = 1 withdrawal + 1 infusion
 Two complete perfusion cycles (two withdrawals and two infusions)
 correspond to 16 culture volume exchanges per day*